

**ABELL**<sup>®</sup>  
Voice of Abell, Crisp as an Apple

# A560T

INSTRUCTION MANUAL



**ABELL**<sup>®</sup>  
Voice of Abell, Crisp as an Apple  
**ABELL INDUSTRIES CO., LTD**  
www.abell.com.cn sales@abell.com.cn  
Tel: 86-755-26095567 Fax: 86-755-26404666

**ABELL INDUSTRIES CO., LTD**

### Thanks

Thank you for choosing ABELL DMR Digital Radio, we believe it is a wise choice to choose us because we have the latest technology, the most stable components, the most advanced production technology. ABELL radio will provide you with the reliable performance and high quality you demand.

**This user manual apply to: Abell A560T**

### Safety Instruction

Please observe the following safety tips to prevent fire, accidents, personal injury or equipment damage.

- ▶ **Do not** modify the radio or its charger in any way.
- ▶ **Do not** expose the radio to direct sunlight for extended periods of time, or leave near heaters or other heat sources.
- ▶ **Do not** store or use unprotected radios for prolonged periods in areas of high dust or excessive moisture.
- ▶ Users may experience signal interference if the unit is used near devices such as TV or electric generators.
- ▶ If the unit emits smoke or you notice a strange smell, immediately turn off the power, and send it to the closest repair service station.
- ▶ The radios are small but contain high power. It is not uncommon to notice slight warming of the handset. This is normal and the unit may continue to be used.

**If there is any problem with the unit, please contact ABELL or your local distributor.**

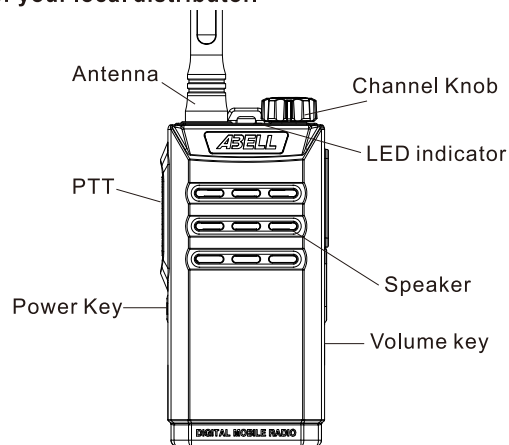

**Turn on**

Turn the Volume/Power knob clockwise to turn the radio on.  
(Some radios are programmed to emit a tone when powered on).

**Turn off**

Turn the Volume/Power knob anticlockwise to turn the radio off, you will hear a sound when the radio is turning off.

**Volume adjustment**

Press and hold down the squelch key off momentarily to hear the continuous beep and turn the volume/power knob to adjust.

**Three way to choose channel**

1. Channel knob: rotate around the "channel choosing button" to choose the channel you need.
2. Channel button: choose the channel you need.
3. Input: when the keyboard mode is the channel mode, you can directly input channel number to change the channel to your need.

**Transmit and receive**

Press PTT button, the two way radio will in the transmit state, the red light will turn on, ICD display will shows  
Release PTT button, the two way radio will in the receive state, the green light will turn on when receive voice data, LCD display will shows

**ABELL Radios Quality Warranty and Liability****The warranty range and limitation**

ABELL is committed to quality and stands behind its products. ABELL will, during the warranty period specified for each product, repair or replace components that fail as a result of poor workmanship or materials. This warranty does not cover improper use or intentional damage.

**The warranty policy not include the following conditions:**

1. Defects or damages caused by working in abnormal or unusual situations.
2. Defect or damages caused by misuse, accident, or water submersion.
3. Defect or damages caused by unauthorized installation, repair, tampering or adjustment.
4. Warranty does not extend to cosmetic scratches or damages as a result of normal use or misuse.
5. This warranty is void if:
  - (a) the product information label on the back aluminum case is removed, or if the serial number is tampered with, changed, or cannot be identified.
  - (b) If the battery case is damage, tampered with, or unsealed.

**General Items**

This warranty policy establishes the liability limits for which ABELL is responsible  
ABELL has the right to decide, in their sole discretion, whether to repair, replace, or refund the purchase price of any equipment subject to this warranty. There are no other options available under this warranty. This express warranty is the complete agreement. **OTHER THAN AS EXPRESSLY SET OUT IN THESE TERMS OR ADDITIONAL TERMS, NEITHER ABELL NOR ITS SUPPLIERS OR DISTRIBUTORS MAKE ANY SPECIFIC PROMISES ABOUT THE SERVICES OR PRODUCTS.**

## CONTENT

Unpacking and device check	1
Accessory	1
Battery information	2
Battery protection	2
Battery Usage	3
Battery charge	3
Preparation	4
Installing the battery	4
Assemble the antenna	4
Assemble the belt clip	5
Disassemble the belt clip	5
Insert the earphone	5
Function key	6
Charging the Battery	7
Charger Indicator	7
LED Indicator of Transceiver	7
Function and basic operation	8
Digital Channel Information	10
Digital mode setting	12
Safty information	13

## Unpacking and device check

Please take the radio out of the package carefully, and before abandon the package material, we advise you to check the accessories according to the following list. If any part is lost or damage, please give the claim letter to the carrier or deliverer.

### Accessories

Items	quantity
Antenna	1
Belt clip	1
Power supplier	1
Battery	1
Charger	1
Lanyard	1
Instruction manual	1
Warranty card	1



Antenna

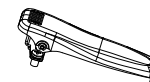

Belt clip



Lanyard

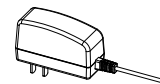

Power supplier



Charger



1600mAh  
Li-ion battery

## Battery information

### Battery protection

ABELL radios use lightweight, environmentally friendly lithium batteries as a power source. The following battery tips will help you to get the best performance and prolong the battery life of your equipment.

1. Be sure to use the original ABELL charger to charge the battery.
2. When charging radios, please power off the radios to ensure battery can be fully and effectively charged.
3. New, uninstalled batteries can be stored for long period, but should be stored in a cool, dry place. (These should be recharged once every three months to maintain the battery's electrical properties, otherwise it will be damaged and will not function properly).
4. New batteries need to be fully charged before use.
5. Use only the battery charger and power supply specified by ABELL. Use of non-authorized charging systems will void the warranty of both the battery and the equipment.
6. Avoid extreme temperatures as this will effect capacity of the battery.
7. The battery cannot be stored in hot or cold places, otherwise it will reduce battery capacity and useful life. The battery should always be stored at normal temperature, and radios equipped with cold batteries may temporarily not work, even if fully charged.
8. Do not let the metal stripes on the battery come into contact with metal objects (such as metal benches, pins, etc) as this may cause the battery to short circuit.
9. Always dispose of old or damaged batteries In accordance with local recycling laws.
10. **NEVER** discard or expose batteries to fire, this will result explosion and serious injury or death.

### Battery Usage

1. Do not use, install or attempt to charge damaged batteries.
2. Do not use batteries in any other equipment other than that which it is designed for.
3. Battery charging time varies and is determined by the remaining capacity of the battery and the battery and charger type. The battery can be repeatedly charged and discharged more than 300 times, but they will age with use. Aging will occur quicker when batteries are used for short periods and then recharged. Batteries should be allowed to fully discharge before charging to prolong battery life.
4. Batteries that are stored and unused discharged over time.

### Battery charge

When the usage is very low, you can not use the radios.

1. The battery should connect with the two way radios charge together or along. Please close the two way radios' power supply.
2. The charger indicator shows the charge state:

Indicator	Current state
Red light flash	Waiting for charge
Red light glows	During charging
Green light glows	Charge complete

## Preparation

### Installing the battery

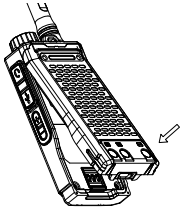

Align the battery with the rabbet

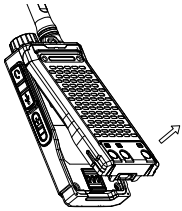

Push and press down until “click” in

### Assemble the antenna



Lift the metal cover, then press down the “lock” to release the battery to take the battery down.

“

### Assemble the belt clip

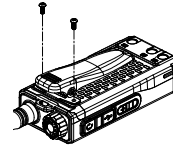

Assemble: Fix the belt clip in the upper end of rear side with two screws until they are screwed down.

### Disassemble the belt clip

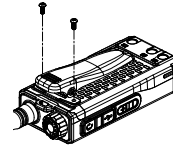

Disassemble: Disassemble the two screws from the belt clip with a screwdriver

### Insert the earphone



Open the rubber cover to insert the Earphone.

## Function key

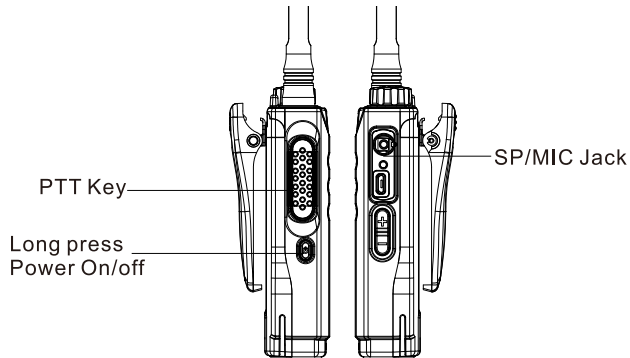
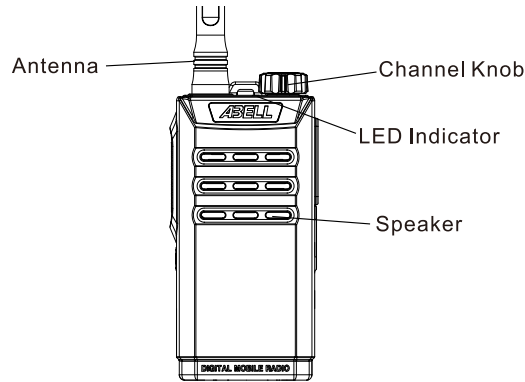

## Charging the Battery

Use only the charger and battery specified by Abell. Charger LED can indicate the charging process.

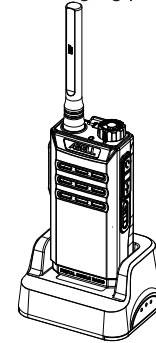

### Charger Indicator

Indicator	Charge Status
Red flash	Standby
Red glows	Charging
Green glows	Fully charged

### LED Indicator of Transceiver

Indicator	charge Status
Green glows 2-3S	starting up
Green glows	receiving signal
Green flash	received
Red glows	transmitting
Red flash	Battery low, will be issued a low battery beep, please charge or replace the battery as soon as possible to ensure that the product to maintain normal work.

## Function and basic operation

### Turning your radio on and off

Power on: Press the Power Key , after the Beep the radio on, a prompt tone will be announced after power on if the radios pre-programmed to have prompt tone, otherwise, no prompt tone.

Power off: Long press Power Key 3S, after the Bee, the radio off.



### Select Channel

Rotate channel selector to choose channel. A prompt tone will be announced after opening the channel annunciation function. If you hear beep continuously which indicate that the channel has been programmed.

### Push-to-talk operation

Switch the channel selector to the channel needed.

Transmit: Hold the radio in a vertical position with the microphone 2 cm away from your lip, press PTT, speak to the MIC.

Receive: The LED Indicator turns in green , when receive signals, while the speaker making sounds. Adjust Volume Key  to change the audio volume.

### Functional Power Key

Key		Functions
K1	Long Press	Non-functional; Power switching; Steady-state monitoring [analog]; Steady cancelation [analog]; Scanning; One-touch call 1 -4(DMR); broadcast local ID; broadcast channel digital; broadcast power; broadcast battery power; broadcast channel type; serial port reported; zone switch
	Short Press	Power on/ off

### Functional key

#### Non-functional

No function programmed(Invalid key, error beep)

### Power switch

Press this button to switch between high and low power

### Steady state (analog)

If not automatically reset the state, press the key is in the listening state, press the key again to exit the monitoring state

### Steady Cancel Squelch(analog)

Press the key to disable noise squelch when steady-state cancel squelch key; press again to cancel squelch key to exit noise squelch.

### Scanning

Press this button to turn the scan on or off

Press the programming scan key after the "beep" sound prompts to enter the scan, and then flash green light, then press the key prompts two "beep" to exit the scanning state.

One Key calling 1-4(DMR)

One key calling function including SMS, Voice call.Operation: To enable the feature, press the programmed key, then hold the PTT to launch the call.

### Broadcast channel digital

Broadcast intercom current channel

### Broadcast power

Broadcast intercom current power

### Broadcast battery power

Broadcast the current intercom battery power

### Broadcast channel type

Intercom broadcast current channel type, digital or analog

### Zone switch

Press to switch the Zone



## Digital Channel Information

**Function:** Set digital channel digital protocol related parameters

**Local number:** The unique code used to identify a person in a digital system when talking on a digital channel.

**Group Call maintained Time:** Users can extend group call status after calling by setting this feature via programming software.

During this period, each member of this group can call back directly.

**Private Call maintain Time:** Users can extend group call status after calling by setting this feature via programming software.

During this period, each unit can call back directly.

**Transmit pre-carrier time:** Pre-carrier is loaded before the data or control information in the message (text message, private call, etc.) before a string of information (extended message), increasing the chances of the receiver to detect the message.

Setting transmit pre-carrier time takes up channel resources, which you can set based on your needs and operating modes.

For example, scan to increase the probability of the scan stay, which is the machine function

### Time out timer(TOT)

To prevent the occupation of the channel too long, but also to prevent the walkie-talkie due to long-term transmission caused by damage to the machine.

**Timeout:** You can set the maximum time that the transceiver is allowed to transmit continuously. The intercom emits a warning tone and stops transmitting when the scheduled timer expires.

**Early warning time:** You can set how long the intercom will issue a "warning tone" before the time-out timer (TOT) expires. When the "warning tone" rang for a specified amount of time, the timeout timer expires

**Retransmission time:** Set the time from the start of the barring (TOT time) to the time of allowing the transmission again. When this time has not expired, press the PTT will be banned warning sounds.

**Reset time:** PTT is released before TOT does not time out, timer starts to count, and when PTT is pressed again, timer TOT is re-timed if the timer exceeds the set value; if not set, TOT time continues to count, The set value is the reset time.

**Operation:** Use the Abell programming software to set this feature.

### Power

The power level indicates the size of the transmit power when the transceiver is working, and the transceiver can set the power level according to the actual requirements. When the requirements of communication distance, the quality of the call can choose the radio high-power working condition; when the required communication distance is near, the call quality of the general case of low-power Raiois can be selected to reduce energy consumption and extend the use of time.

Value range: low power / high power

Default: low power

Power level table

Power level	Power(W)
High power	5W
Low power	1W

## Digital mode setting

### Receiving Groups List

This feature allows users receive several different groups calls on one Digital Channel

Value Range: Group Call List 1- Group Call List 32

Default: Group Call List 1

### Transmitting Groups List

Select the people you want to call from the contact list.

Value Range: Contact list 1- Contact 512

Default: Contact Call List 1

### DMR

DMR uses TDMA technology which allows two simultaneous conversations with in a 12.5kHz Channel without any interference.

### TDMA Direct Mode

Under TDMA direct mode one channel allows two simultaneous conversations. Every unit of one group has to use the same Time division which can avoid interference.

### Operation

This feature has been turned on via programming software. After this feature been turned on, switch to Digital channel of TDMA select mode manually or turn on the unit at the Digital channel of TDMA select mode, which can enter TDMA Direct Mode.

## Safety information

This manual provide you with safe and ease instruction for our ABELL portable two-way radio.



### Operation and Electro magnetin exposures

Press PTT(push to talk), hold the radio in a vertical position with the microphone 2.5 to 5cm(1 to 2 inches) away from the lips. And make the antenna 2.5cm away from your head or body when transmit.

### Electromagnetic interference (EMI) /Electromagnetic compatibility

Note: All electronic device will be influenced by EMI if no proper electromagnetic compatibility design was adopted. Close the radio if the airline required when in the plane. And commit to the airline's requirements when using the radio in the plane.

### Operation warning

Car with safty air bay restraint system Don't put the portable radio on the top or in the range of the car air bag for fear of hurting when the air bag is open suddenly

### Environment with explosion risk

Please turn off the radio in the environment with explosion risk, unless your radio has gotten the FM or Cenelec Certificate. In such environment, even little electric spark can lead to explosion, fire, damage or death.

### Battery

Don't change or charge the battery in the environment with explosion risk. Since it may cause flames and leads to Explosion.

**In the blast area or area with detonator**

Please turn off your radio in advance when you are near from the In the blast area or area with detonator.

**Operation instruction****Damaged antenna**

Stop using the damaged antenna. The damaged antenna may burn your skin when using it.

**Battery**

If any metal conductor such as jewelry accessory, keys or necklace touch battery's electrode, that may cause fire, heat to hurt people. Be careful when putting the fully charged battery in the pocket, leather case or other container with metal.

**Radio's maintainance**

- 1.The chemical material such as alcoholic,petroleum will hurt the radio surface.
- 2.Please take the radio softly, do not pick the radio by griping the antenna, which may easily break the antenna.
- 3.Please close the dust proof cover to protect the Microphone/ speaker jack while not using accessory.
- 4.Clean the surface of the radio with wet cloth and make sure that no water enter it.
- 5.Unrecognized accessories may damage the radio and in this case our warranty will be unavailable.